

# IoT-Based Solar Power Plant Parameter Monitoring System

Azwa Soleha<sup>1\*</sup>, Jefri Lianda<sup>2</sup>, Adam<sup>3</sup>

<sup>1,2,3</sup>Department of Engineering, Politeknik Negeri Bengkalis, Jl. Bathin Alam, Sungai Alam, Bengkalis District, Bengkalis Regency, Riau, Indonesia

\* Corresponding author: Azwa Soleha

Email: [azwasolehaazwa@gmail.com](mailto:azwasolehaazwa@gmail.com)

---

## **Abstract.**

*The utilization of Solar Power Plants (plts) as a renewable energy source continues to increase in line with the growing demand for environmentally friendly energy. However, the performance of an SPP is highly influenced by environmental conditions and variations in its electrical parameters. Therefore, a monitoring system capable of providing real-time information and remote access is required. This study aims to design and implement an Internet of Things (IoT)-Based Solar Power Plant Parameter Monitoring System to monitor key parameters such as voltage, current, power, and solar panel temperature. The system uses an ESP32 microcontroller as the main processing unit connected to various measurement sensors. The collected data are transmitted through the internet to a monitoring platform, allowing users to observe the condition of the solar power plant in real time using mobile devices or computers. System testing was conducted to evaluate sensor reading performance, data communication stability, and overall monitoring system functionality. Data collection was carried out from a Solar Power Plant (SPP) between 09:00 AM and 03:00 PM. The results showed that the system was able to monitor and transmit solar power plant parameters in real time with good accuracy and reliability. The implementation of IoT technology in this monitoring system is expected to improve maintenance efficiency, reduce the risk of system failures, and support the optimization of solar power plant performance in generating electrical energy.*

**Keywords:** Current, monitoring, temperature, real time and voltage.

---

## **I. INTRODUCTION**

The utilization of renewable energy has continued to increase along with the growing demand for electrical energy and the rising awareness of the negative environmental impacts caused by the use of fossil fuels. One of the most potential renewable energy sources is the Solar Power Plant (SPP), which utilizes solar radiation energy and converts it into electrical energy through solar panels [1]–[3]. In addition to being environmentally friendly, solar power plants also have the advantage of abundant energy availability, especially in tropical regions such as Indonesia [5].

However, the performance of solar power plants is strongly influenced by several factors, including solar light intensity, panel surface temperature, and load conditions. Changes in the temperature of solar panels can reduce energy conversion efficiency, while fluctuations in light intensity directly affect the voltage and current generated [6], [9]. Therefore, monitoring parameters such as voltage, current, power, and temperature is very important to determine the overall performance of the system [7].

In general, the monitoring process of solar power plants is still carried out manually or limited to local measurements, making it less efficient and unable to provide real-time information. This condition makes it difficult for users to analyze system performance and detect disturbances or performance degradation at an early stage. To overcome these problems, a monitoring system that can operate automatically, continuously, and be accessed remotely is required [7], [8].

The development of Internet of Things (IoT) technology provides a solution for creating smarter and more integrated monitoring systems. By utilizing IoT technology, data from various sensors can be collected, processed, and transmitted through internet networks, allowing real-time monitoring through devices such as smartphones or computers. Several studies have shown that IoT-based monitoring systems can improve the operational efficiency of solar power plants and simplify the system evaluation process [8]–[10].

Based on these considerations, this study aims to design and develop an IoT-based monitoring system for solar power plant parameters using a DHT22 sensor for temperature measurement, a ZMPT101B sensor for voltage measurement, and a current sensor to monitor electrical current. The obtained data are processed by the ESP8266 microcontroller and transmitted to a cloud-based platform to be displayed in the form of a

dashboard. This system is expected to provide accurate, real-time, and easily accessible information regarding the condition of the solar power plant, thereby improving monitoring efficiency and assisting decision-making related to the management and maintenance of solar power systems [9], [10].

## II. METHODS

This research uses a design and implementation method based on the Internet of Things (IoT) to monitor parameters in a Solar Power Plant (SPP) system in real-time. The initial stage was conducted through direct observation and literature study to understand the concepts of solar power systems, measurement sensors, and IoT-based data communication technology. Furthermore, a system requirements analysis was carried out to determine the parameters to be monitored, namely voltage, current, power, and solar panel temperature [11].

The system design was divided into two aspects: hardware and software design. The hardware consists of solar panels, voltage sensors, current sensors, temperature sensors, and an ESP32 microcontroller that functions as the main data processing center. The software was designed to read data from the sensors, process the data, and transmit it to the monitoring platform.

An external ADC was used to improve the accuracy of analog signal readings from the sensors, especially for more precise voltage measurements. This is necessary because the internal ADC on the ESP32 has limitations in terms of resolution and stability. Therefore, the external ADC helps produce more accurate and stable data.

The DHT22 temperature sensor was used to measure the environmental temperature or the surface temperature of the solar panels. Temperature is one of the important parameters because it can affect the efficiency of solar panels. This sensor has a fairly good level of accuracy and is capable of transmitting temperature data digitally to the ESP32.

The voltage sensor was used to measure the voltage generated by the solar panels. This sensor works by reducing (step-down) the voltage so that it can be safely read by the microcontroller without damaging the components. The voltage data are used to detect whether the panel operates normally or experiences a performance decrease.

The INA219 current and power sensor is capable of simultaneously measuring current, voltage, and power. This sensor communicates using the I2C protocol, making it easy to integrate with the ESP32. Data obtained from the INA219 sensor are very important for determining the power generated by the panels and evaluating the overall efficiency of the system. The data analysis can also identify whether a panel experiences performance degradation compared to other panels [12]-[13].

Furthermore, testing was carried out to ensure the accuracy of sensor readings, the stability of data transmission, and the ability of the system to perform real-time monitoring. The obtained data were then analyzed to evaluate the performance of the designed solar power plant monitoring system [14].

The research procedure began by analyzing current, voltage, power, and temperature data from the solar panels to identify problematic panels. For example, if the voltage of panel 1 drops while the other panels remain normal, the system will indicate that panel 1 is experiencing a problem. Each panel only displays information related to its condition and performance [11]-[15].

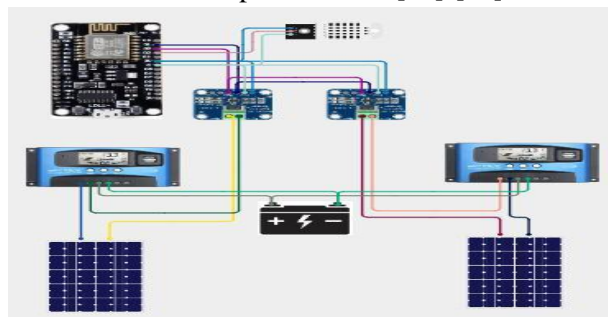

**Fig. 1. Hardware Design**

The measurement results were analyzed descriptively and comparatively to determine which panel experienced problems, such as when panel 1 showed a voltage drop while panel 2 remained normal. The analysis was conducted by presenting the data in the form of tables and graphs to clearly illustrate changes in temperature, current, voltage, and power. The analysis results were used to draw conclusions regarding the effectiveness of the solar panel performance monitoring system and to evaluate the potential of the IoT-based solar power plant parameter monitoring system.

### III. RESULT AND DISCUSSION

The Testing was conducted on April 17, 2026, at the Politeknik Negeri Bengkalis environment. Data were collected during the period of highest solar intensity, from 09:00 AM to 03:00 PM WIB. The measured parameters included voltage (V), current (I), and solar panel surface temperature (T).

**Table 1. Performance of Solar Power Plant  
Based on Solar Panel Temperature**

Time	Temperature (°C)	Voltage (V)	Current (A)	Power (W)
09.00	32.2	12.8	1.1	14.9
10.00	32.2	12.9	1.2	15.36
11.00	31.8	12.10	1.4	16.95
12.00	31.6	12.11	2.2	26.64
13.00	35.7	13.6	2.4	30.24
14.00	35.6	13.7	2.6	35.67
15.00	35.2	13.9	2.6	38.64

Based on Figure 2, which presents the comparison graph of solar panel voltage with and without a cooling system, it can be observed that the voltage values under both conditions tend to increase as solar radiation intensity increases from 09:00 AM until reaching its peak at midday. However, the solar panel equipped with a cooling system shows more stable and relatively higher voltage values compared to the panel without cooling.

This occurs because the cooling system reduces the surface temperature of the panel, thereby minimizing the negative effects of temperature on the electrical characteristics of photovoltaic cells. Under conditions without cooling, an increase in panel temperature causes a voltage decrease due to increased thermal energy that interferes with electron movement within the semiconductor material. In contrast, with the cooling system, the panel temperature can be maintained at a lower level, allowing the generated voltage to remain optimal.

This difference becomes more visible during maximum radiation conditions, where the panel without cooling experiences more significant voltage fluctuations compared to the cooled panel. Therefore, the graph indicates that temperature has a considerable influence on the output voltage of solar panels, and the implementation of a cooling system is one effective solution to maintain voltage stability and improve overall system performance.

uhan.



**Fig. 2. Voltage Graph of Solar Panels**

The current graph shows an increase from 1.1 A to 2.6 A. The increase occurred gradually. In the first to third data points, the increase was relatively small, indicating low sunlight intensity. At the fourth data point, a significant increase occurred, indicating that solar intensity had become higher. In the sixth and seventh data points, the current remained stable at 2.6 A, indicating stable operating conditions.

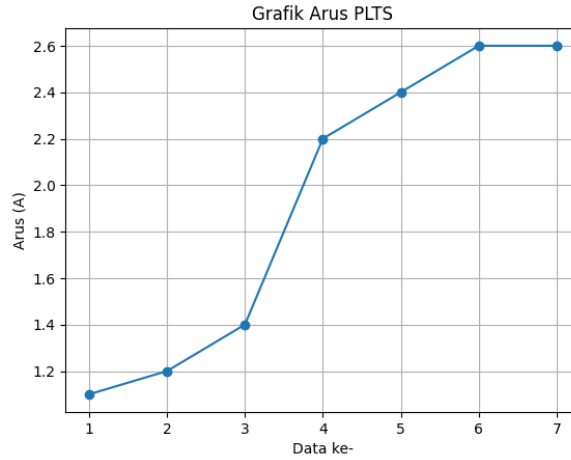

**Fig.3. Current Graph of Solar Panels**

Based on the temperature graph, the first and second data points indicate that the environmental conditions were still normal. A slight decrease to 31.8°C and 31.6°C may have been caused by environmental factors such as clouds and wind. A significant increase occurred from 31.6°C to 35.7°C, indicating a sharp increase in solar intensity. A slight decrease at the end, from 35.7°C to 35.2°C, indicates that the temperature began to stabilize even though it remained relatively high.

Overall, the temperature tended to increase over time, and temperature changes were influenced by solar intensity and environmental conditions such as clouds and wind. The solar panel experienced an increase from normal conditions to higher temperature conditions as solar intensity increased, then gradually stabilized at a high temperature level.

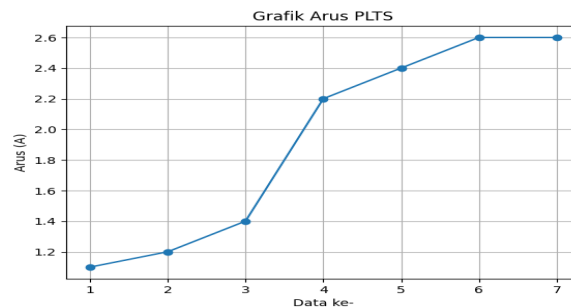

**Fig.4 . Current Graph of the Solar Panel**

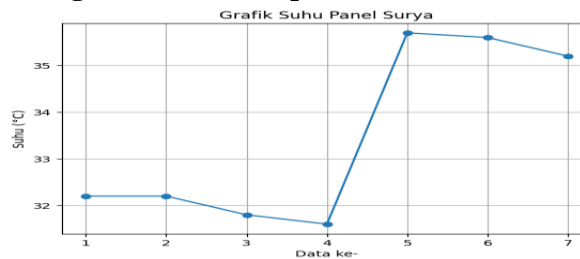

**Fig.5 Temperature Graph of Solar Panels**

Figure 5 shows the power graph, which indicates that the power increased from 14.9 W, demonstrating that the solar panel operated properly as time and measurement conditions progressed. The gradual increase at the beginning, from the first to the third data points, was relatively small, indicating that solar light intensity was still not optimal because measurements were taken in the morning.

A significant increase occurred in the middle of the graph, particularly at the fourth data point, where the power rose sharply from 16.95 W to 26.64 W. From the fifth to the seventh data points, the power continued to increase and reached its highest value, which usually occurs when the sun is at its highest position.

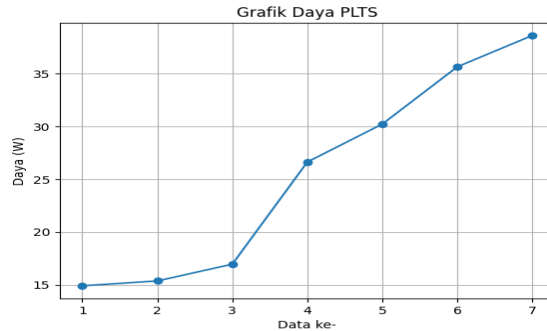

**Fig.6. Power Graph of Solar Panels**

Based on the results of the Internet of Things (IoT)-based monitoring system testing shown in Figure 6, the system was able to perform real-time acquisition, transmission, and visualization of solar panel electrical parameter data effectively. The monitored parameters included voltage, current, and solar panel surface temperature obtained from sensors, processed by the microcontroller, and transmitted to the server through the internet network.

The received data were then displayed through web-based and mobile-based application interfaces (billing system), making it easier for users to perform remote monitoring.



**Fig.7. Monitoring System Display Results**

During the testing process, the system demonstrated stable performance in displaying data continuously and responsively to environmental condition changes. The parameter values displayed in the application were consistent with direct field measurements, indicating that the system has a good level of accuracy.

In addition, no significant delay was found during the data transmission process, indicating that communication between the hardware and server operated optimally. The implementation of this IoT-based monitoring system provides convenience in automatic and integrated data collection and recording processes.

Therefore, this system not only improves efficiency in testing activities but also supports more accurate and systematic solar panel performance analysis, making it highly relevant for implementation in the development of modern Solar Power Plant (SPP) systems.

#### IV. CONCLUSION

Based on the results of the design and testing process, the IoT-based Solar Power Plant (SPP) parameter monitoring system has been successfully developed and implemented properly. This system is

capable of monitoring important parameters such as voltage, current, power, and solar panel temperature in real-time, while displaying the data accurately and continuously through an internet-based platform.

The existence of this monitoring system makes it easier for users to supervise the performance of the solar power plant without having to be physically present at the location, thereby improving operational efficiency and system management activities. In addition, the system also enables early detection of potential disturbances or performance degradation in the solar power plant, allowing corrective actions to be carried out more quickly.

## V. ACKNOWLEDGMENTS

This research was supported by the Electrical Power Simulation Laboratory, Department of Electrical Engineering, Politeknik Negeri Bengkalis. The authors would also like to express their gratitude to Politeknik Negeri Bengkalis for providing financial support for this research.

## REFERENCES

- [1] Waluyo, B. D., Sembiring, M. A. R., Sinaga, N., Lubis, A. A., & Tarigan, S. V. B. (2024). Sistem Monitoring PLTS Berbasis IoT Sebagai Media Pembelajaran. *Jurnal Teknologi Informasi & Komunikasi Dalam Pendidikan*, 11(1). DOI: 10.24114/jtikp.v11i1.60282.
- [2] Wijayanto, D., Haryudo, S. I., Wrahatnolo, T., & Nurhayati. (2022). Rancang Bangun Monitoring Arus dan Tegangan pada PLTS Sistem On-Grid Berbasis Internet of Things (IoT) Menggunakan Aplikasi Telegram. *Jurnal Teknik Elektro*, 11(3), 447–453. DOI: 10.26740/jte.v11n3.p447-453.
- [3] Kurniawan, N., Darman, M. Y., Adriani, & Zainuddin. (2025). Sistem Monitoring Switching PLTS dan Solar Tracker Dual Axis Berbasis IoT. *Vertex Elektro*, 17(2). DOI: 10.26618/jte.v17i2.17579.
- [4] Risnauli, R., Kalsum, T. U., & Mardiana, Y. (2025). Rancang Bangun Sistem Monitoring Konsumsi Energi Listrik pada PLTS Berbasis IoT. *SKANIKA: Sistem Komputer dan Teknik Informatika*, 9(1). DOI: 10.36080/skanika.v9i1.3657.
- [5] Zulhairi, Z., Pristisahida, A. O., Mardhiyyah, R., Prasaja, B. K., Fakhurrozi, A., Amiyanto, T. S., & Machfud, A. A. (2025). Rancang Bangun Sistem Pemantauan Baterai PLTS Berbasis IoT pada Lahan Pertanian. *Jurnal Riset Rekayasa Elektro*, 7(2). DOI: 10.30595/jrre.v7i2.24681.
- [6] Sari, L. O., Saputra, M. F. E., & Safrianti, E. (2024). Sistem Monitoring Arus Listrik Berbasis Internet of Things (IoT) pada Solar Panel di Laboratorium PLTS UIN Suska Riau. *MALCOM: Indonesian Journal of Machine Learning and Computer Science*, 4(1). DOI: 10.57152/malcom.v4i1.1033.
- [7] Abduh, S. R., Lisapaly, L., & Pangaribuan, T. (2024). Disain dan Implementasi Sensor Monitoring Jarak Jauh Berbasis IoT Terhadap Kinerja Panel Surya. *Journal of Renewable Energy, Electrical Engineering, and Artificial Intelligence (JREEEAI)*, 1(1), 19–26.
- [8] Madjowa, T. S., Ilham, J., Hidayat, I., Abdussamad, S., Tansa, S., & Nasibu, I. Z. (2025). Solar Power Plant (PLTS) Power Monitoring System Based on the Internet of Things (IoT) Using the Blynk and Telegram Platforms. *Emitor: Jurnal Teknik Elektro*. DOI: 10.23917/emitor.v26i1.14225.
- [9] Saleem, Y., Crespi, N., Rehmani, M. H., & Copeland, R. (2017). Internet of Things-aided Smart Grid: Technologies, Architectures, Applications, Prototypes, and Future Research Directions. *Future Generation Computer Systems*.
- [10] Gubbi, J., Buyya, R., Marusic, S., & Palaniswami, M. (2013). Internet of Things (IoT): A Vision, Architectural Elements, and Future Directions. *Future Generation Computer Systems*, 29(7), 1645–1660.
- [11] Boubakr, G., Gu, F., Farhan, L., & Ball, A. (2022). Enhancing virtual real-time monitoring of photovoltaic power systems based on the Internet of Things. *Electronics*, 11(15), 2469. <https://doi.org/10.3390/electronics11152469>
- [12] Dos Santos, T. A., Freitas, F. G. de, Gonçalves, D. L. C., & Fernández-Ramírez, L. M. (2022). Design and validation of IoT measurement system for photovoltaic generation. *Ingenius*, 28, 38–49. <https://doi.org/10.17163/ings.n28.2022.04>
- [13] Rao, C. K., Sahoo, S. K., & Yanine, F. F. (2024). A literature review on an IoT-based intelligent smart energy management systems for PV power generation. *Hybrid Advances*, 5, 100136. <https://doi.org/10.1016/j.hybadv.2023.100136>

- [14] Ratnasari, D. A., Suprianto, B., & Baskoro, F. (2022). Monitoring daya listrik pada panel surya berbasis Internet of Things (IoT) menggunakan aplikasi Telegram. *Indonesian Journal of Engineering and Technology (INAJET)*, 5(1), 1–10. <https://doi.org/10.26740/inajet.v5n1.p1-10>
- [15] Winardi, B., Nugroho, A., & Alvin, Y. (2022). Monitoring and automatic cooling systems in realtime photovoltaic based on IoT. *Bulletin of Computer Science and Electrical Engineering*, 3(2), 55–65. <https://doi.org/10.25008/bcsee.v3i2.1164>.